

PROPERTY OF GENERAL SCANNING
 This document is and shall remain an unpublished work of General Scanning protected by copyright. It is loaned for limited purposes only, remains the property of General Scanning, and is to be returned upon request. Neither it nor any of the information it contains will be reproduced, used, or disclosed to anyone not having a need-to-know consistent with the purpose of the loan, without written consent of General Scanning.

SYM	REVISION	RECORD	DATE	APPVD.
R	PER ECN 8822			
S	REV MARKING PER ECN 9038			
T	REV PER ECN 9097		6/9/94	S.F.L.
SEE TABLE	REV MARKING PER ECN 10352			

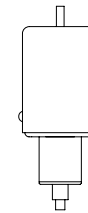
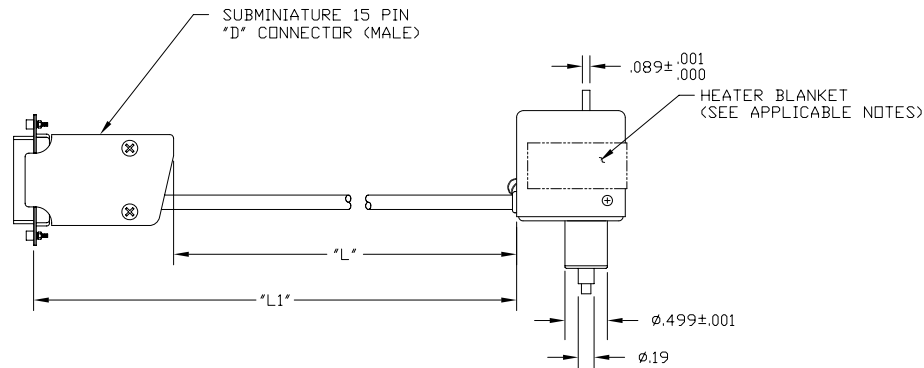
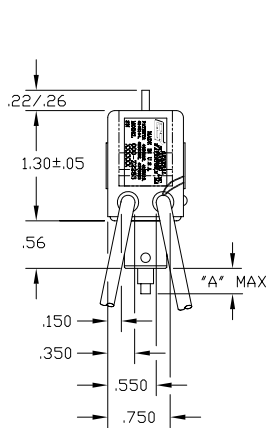
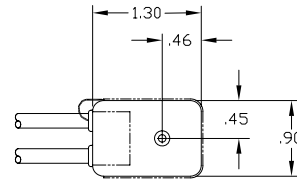

DASH	MODIFIED SHAFT	"L"	"L1"	APPLICABLE NOTES	HUB "A" MAX	REV
-1		9±1		2, 3, 6		U
-2		9±1		2, 4, 6	.30	U
-3		17±1		2, 3, 6, 7		U
-4	YES	9±1		2, 3, 6	1.05	U
-5	YES	9±1		2, 4, 6		U
-6	YES		20.68±1	3, 6	.30	U
-7			72.00±1	2, 3, 6, 7	.30	A

NOTES:

-
- NAME PLATE MAY BE SUBSTITUTED BY LASER MARKING AS PER M0570.
- HEATER BLANKET NOT USED.
- HEATER BLANKET USED.
-
- ALL DIMENSIONS ±.020 UNLESS OTHERWISE SPECIFIED.
- INDIVIDUALLY PACKAGED (PG BOX + G1 INSERT)

MATERIAL				TREATMENT					
UNLESS SPECIFIED: DIMENSIONS ARE IN INCHES TOLERANCES: .XX = ± .01 .XXX = ± .005 .XXXX = ± .0010 ANG. = ± 0°30'				FUNCTION	NAME	DATE	CAD FILE No.	OPT\06017-0U	CAGE No.
REMOVE ALL BURRS AND SHARP EDGES				DRAWN	G. TOBIASON	5-3-82	TITLE		
SCALE 1=1 in [mm]				CHECKER			OUTLINE		
				DES. ENG.	W. REIMELS		GENERAL SCANNING		
				MFG. ENG.			SIZE C	DRAWING NUMBER 3CD-06017	REV SEE TABLE
				PROJ. MGR.	D. TWEED		INCORPORATED WATERTOWN MA		

S	9038	X
R	8822	X
DIT 2	DIT 1	NUMBER
CAD FILE REV.		

NOTES:
 1. ALL DIMENSIONS ±.020 UNLESS OTHERWISE SPECIFIED.

REVISIONS				
ZONE	REV	DESCRIPTION	DATE	APPROVED
-	SEE TABLE	REVISED PER ECO # 2002-134		

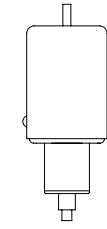
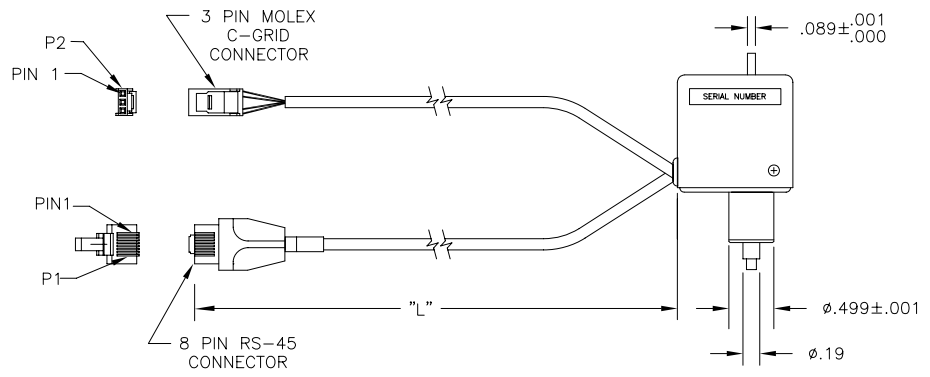
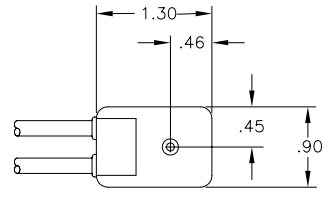
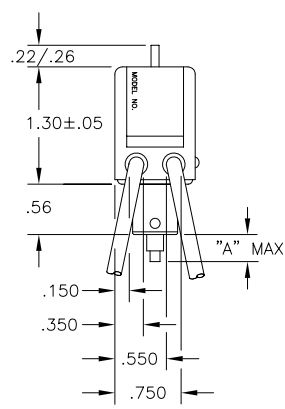

- P1
- 1 VIOLET
 - 2 BLACK
 - 3 ORANGE
 - 4 WHITE
 - 5 BROWN
 - 6 RED
 - 7 NO CONNECTION
 - 8 NO CONNECTION

- P2
- 1 YELLOW / BLACK
 - 2 RED / GREEN
 - 3 NO CONNECTION

DASH	MODIFIED SHAFT	"L"	HUB "A" MAX	REV
-1		12±0.5	.30	C
-2		39±0.5		C
-3		78±0.5		C
-4	YES	12±0.5	1.05	A
-5	YES	39±0.5	1.05	A
-6	YES	78±0.5	1.05	A

UNLESS OTHERWISE SPECIFIED:
 DIMENSIONS ARE IN MILLIMETERS.
 TOLERANCES ARE:
 X ± .1
 XX ± .01
 XXX ± .005
 XXXX ± .0010
 ANGLES ± .5°
 DO NOT SCALE DRAWING
 REMOVE ALL BURRS AND BREAK SHARP EDGES
 ALL MACH SURFACES 63/

INTERPRET DRAWING IN ACCORDANCE WITH DOD-STD-100, ANSI Y14.5M PROPERTY OF GSI LUMONICS THIS DOCUMENT IS AND SHALL REMAIN AN UNPUBLISHED WORK OF GSI LUMONICS. PROTECTED BY COPYRIGHT, IS LOANED FOR LIMITED PURPOSES ONLY. REMAINS THE PROPERTY OF GSI LUMONICS, AND IS TO BE RETURNED UPON REQUEST. NEITHER IT NOR ANY OF THE INFORMATION IT CONTAINS WILL BE REPRODUCED, USED, OR DISCLOSED TO ANYONE NOT HAVING A NEED-TO-KNOW CONSISTENT WITH THE PURPOSE OF THE LOAN, WITHOUT WRITTEN CONSENT OF GSI LUMONICS.		UNLESS OTHERWISE SPECIFIED: DIMENSIONS ARE IN MILLIMETERS. TOLERANCES ARE: X ± .1 XX ± .01 XXX ± .005 XXXX ± .0010 ANGLES ± .5° DO NOT SCALE DRAWING REMOVE ALL BURRS AND BREAK SHARP EDGES MACHINED SURFACES 16 MICRON	Gsi Lumonics COMPONENT PRODUCTS GROUP DRAWN: A. VALLEE 03-13-97 DESIGN ENG: J. W. KING 05-19-97 MFG ENG: D. BROWN 05-19-97	OUTLINE G1--DS	SIZE: C CAGE CODE: 57246 DWG NO.: 310-18346 REV: SEE TABLE
THIRD ANGLE PROJECTION		CAD FILE NAME: 18344-0c	SCALE: 1/1	SHEET 1 OF 1	SHEET 1 OF 1

REVISIONS				
ZONE	REV	DESCRIPTION	DATE	APPROVED
-	SEE TABLE	REVISE PER ECO-2001-160		

NOTES:
1. ALL DIMENSIONS ±.020 UNLESS OTHERWISE SPECIFIED.

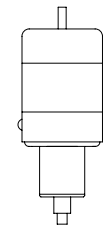
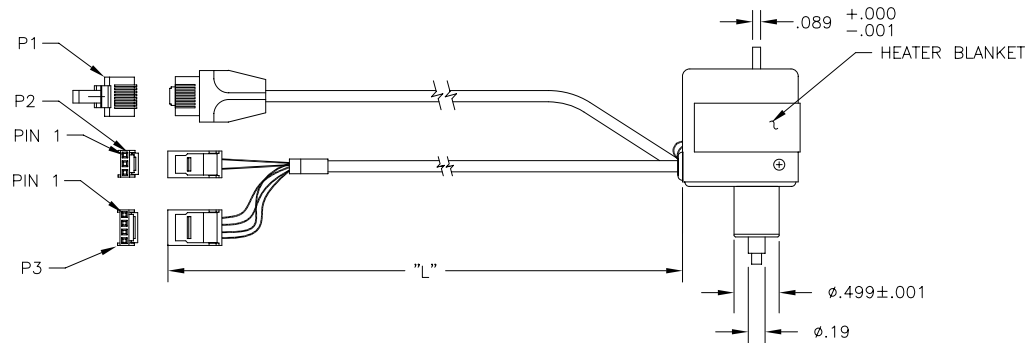
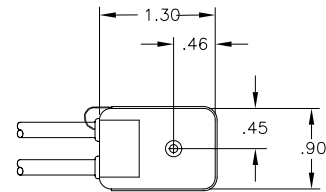
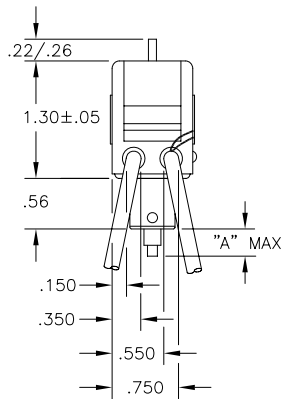

- P3
- 1 RED
 - 2 RED
 - 3 BLUE
 - 4 BLUE

- P2
- 1 RED
 - 2 YELLOW
 - 3 NO CONNECTION

- P1
- 1 VIOLET
 - 2 BLACK
 - 3 ORANGE
 - 4 WHITE
 - 5 BROWN
 - 6 RED
 - 7 NO CONNECTION
 - 8 NO CONNECTION

- DETAIL A
- P2
- 1 YELLOW / BLACK
 - 2 RED / GREEN
 - 3 NO CONNECTION

DASH	"L"	HUB "A" MAX	REV	DETAIL
-1	12±0.5		C	
-2	39±0.5	.30	C	A
-3	78±0.5		C	
-4	12±0.5	1.05	B	
-5	39±0.5		B	
-6	78±0.5		B	

INTERPRET DRAWING IN ACCORDANCE WITH DOD-STD-100, ANSI Y14.5M		UNLESS OTHERWISE SPECIFIED: DIMENSIONS ARE IN INCHES TOLERANCES ARE: XX ± .1 XXX ± .01 XXXX ± .005 XXXXX ± .0010 ANGLES ± .5° DO NOT SCALE DRAWING REMOVE ALL BURRS AND BREAK SHARP EDGES ALL MACH SURFACES		gsi Lumonics 4E Crosby Drive, Bedford, Massachusetts, USA 01730	
PROPERTY OF GSI LUMONICS THIS DOCUMENT IS AND SHALL REMAIN AN UNPUBLISHED WORK OF GSI LUMONICS PROTECTED BY COPYRIGHT. IS LOANED FOR LIMITED PURPOSES ONLY. REMAINS THE PROPERTY OF GSI LUMONICS, AND IS TO BE RETURNED UPON REQUEST. NEITHER IT NOR ANY OF THE INFORMATION IT CONTAINS WILL BE REPRODUCED, USED, OR DISCLOSED TO ANYONE NOT HAVING A NEED-TO-KNOW CONSISTENT WITH THE PURPOSE OF THE LOAN, WITHOUT WRITTEN CONSENT OF GSI LUMONICS.		DRAWN KEN WYNN 3/4/97	DESIGN ENG J.W. KING 4/18/97	OUTLINE G1__DTS	
THIRD ANGLE PROJECTION 		MFG ENG D.C. BROWN 5/18/97	SIZE C	CAGE CODE 57246	DWG NO. 3CD-18167
CAD FILE NAME: 18167-0C		SCALE 1/1	REV SEE TABLE		SHEET 1 OF 1

4

3

2

1

DWG NO. 3CD-10806

SH 1 REV 001

NOTES:

1. LABEL AFFIXED SIDE "X"
2. LABEL AFFIXED SIDE "Y"
3. STATOR FACED OFF.
4. HEATER BLANKET NOT USED.
5. HEATER BLANKET USED.
6. SEE SHEET 2.
7. RETAINER SCREWS LATCHING HARDWARE USED.
8. NO LATCHING HARDWARE USED.
9. LABEL METRIC USED.

REVISIONS			
ZONE/REV	DESCRIPTION	DATE	APPROVED
- / SEE TABLE	REVISED PER ECO 990270		

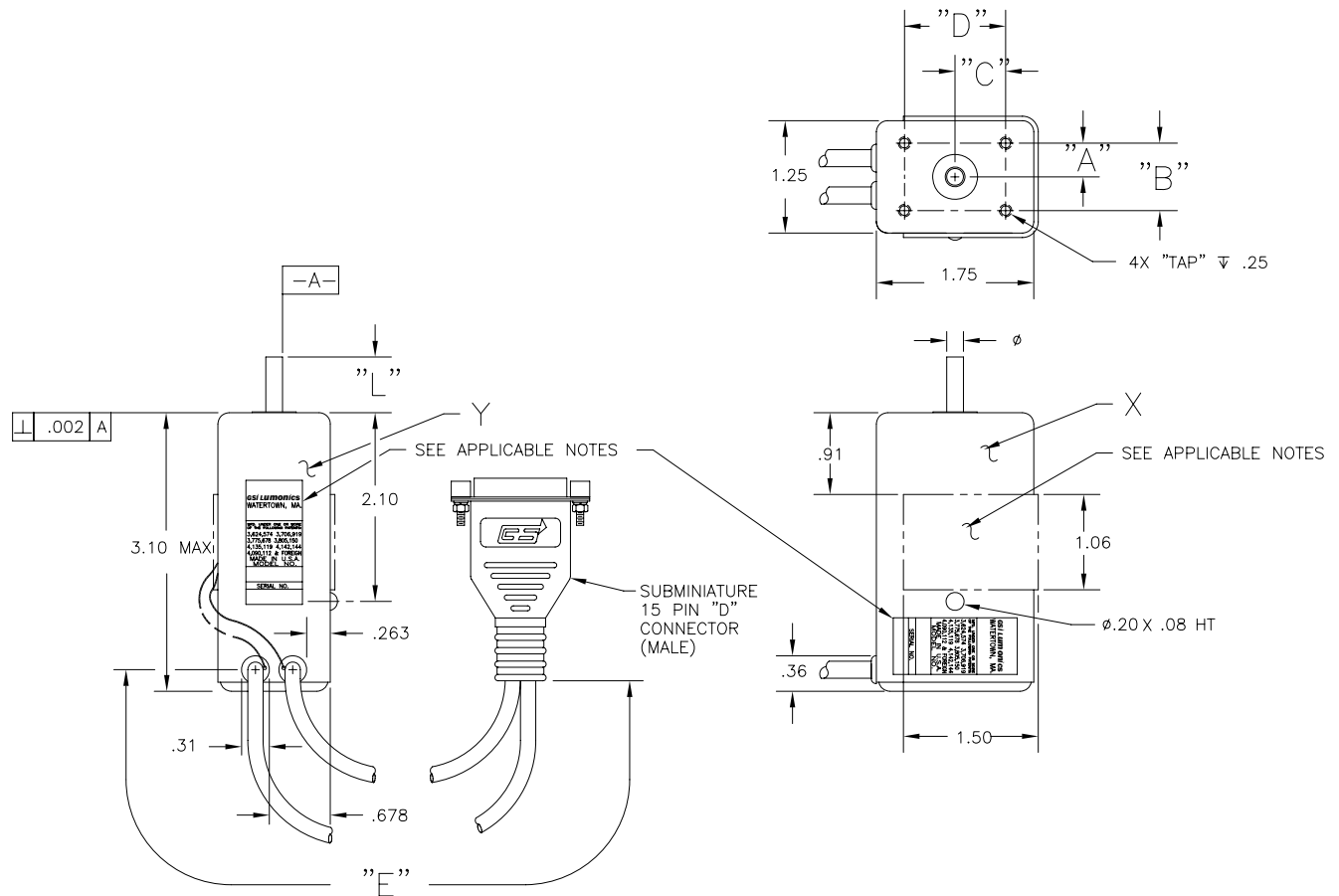

REV	DASH	SHAFT		TAP SPACING				TAP SIZE	LEADS FROM	APPLICABLE NOTES	E ±1.00
		L±.05	ø	A	B	C	D				
D	-1	.62	(.187)	.375	.750	.562	1.125	6-32 UNC-2B	SIDE	1,3,4	9
	-2	.62	(.187)	.375	.750	.562	1.125	6-32 UNC-2B	SIDE	1,3,5	9
	-3	.62	(.187)	.375	.750	.562	1.125	M3 X 0.5mm	SIDE	1,3,5	9
	-4	.62	(.187)	.375	.750	.562	1.125	M3 X 0.5mm	SIDE	1,3,4	9
	-5	.62	(.187)	.375	.750	.562	1.125	M3 X 0.5mm	SIDE	1,3,5,6,7	9
C	-6	.62	(.187)	.375	.750	.562	1.125	6-32 UNC-2B	SIDE	1,3,5	27.75
D	-7	.62	(.187)	.375	.750	.562	1.125	6-32 UNC-2B	SIDE	1,3,4,7	9
C	-8	.62	(.187)	.450	.900	.700	1.400	6-32 UNC-2B	SIDE	1,3,5,8	9
	-9	.62	(.187)	.375	.750	.562	1.125	M3 X 0.5mm	SIDE	1,3,5,9	9
	-10	.62	(.187)	.375	.750	.562	1.125	M3 X 0.5mm	SIDE	1,3,4,9	9

SHEET 1 OF 2

INTERPRET DRAWING IN ACCORDANCE WITH DOD-STD-100, ANSI Y14.5M-1994		UNLESS OTHERWISE SPECIFIED: DIMENSIONS ARE IN INCHES TOLERANCES ARE: XX ± .01 XXX ± .005 XXXX ± .0010 ANGLES ± .5° DO NOT SCALE DRAWING REMOVE ALL BURRS AND BREAK SHARP EDGES		gsi Lumonics 500 ARSENAL STREET, WATERTOWN, MA 02472	
PROPERTY OF GSI LUMONICS THIS DOCUMENT IS AND SHALL REMAIN AN UNPUBLISHED WORK OF GSI LUMONICS PROTECTED BY COPYRIGHT. IS LOANED FOR LIMITED PURPOSES ONLY. REMAINS THE PROPERTY OF GSI LUMONICS, AND IS TO BE RETURNED UPON REQUEST. NEITHER IT NOR ANY OF THE INFORMATION IT CONTAINS WILL BE REPRODUCED, USED, OR DISCLOSED TO ANYONE NOT HAVING A NEED-TO-KNOW CONSISTENT WITH THE PURPOSE OF THE LOAN, WITHOUT WRITTEN CONSENT OF GSI LUMONICS.		DRAWN: P. MACAULAY DESIGN ENG: P. GLYNN MFG ENG: S. LEVESQUE		4-11-91 1-4-88 3-31-88	
THIRD ANGLE PROJECTION		CAD FILE NAME: 10806-0F		OUTLINE, G325D	
SCALE: 1/1		CAGE CODE: 57246		DWG NO.: 3CD-10806	
SHEET 1 OF 1		REV SEE TABLE		REV SEE TABLE	

4

3

2

1

SYM	REVISION	RECORD	DATE	APPVD.
A	REL. TO	PROD	ECO 4833	7-9-85 JZ.

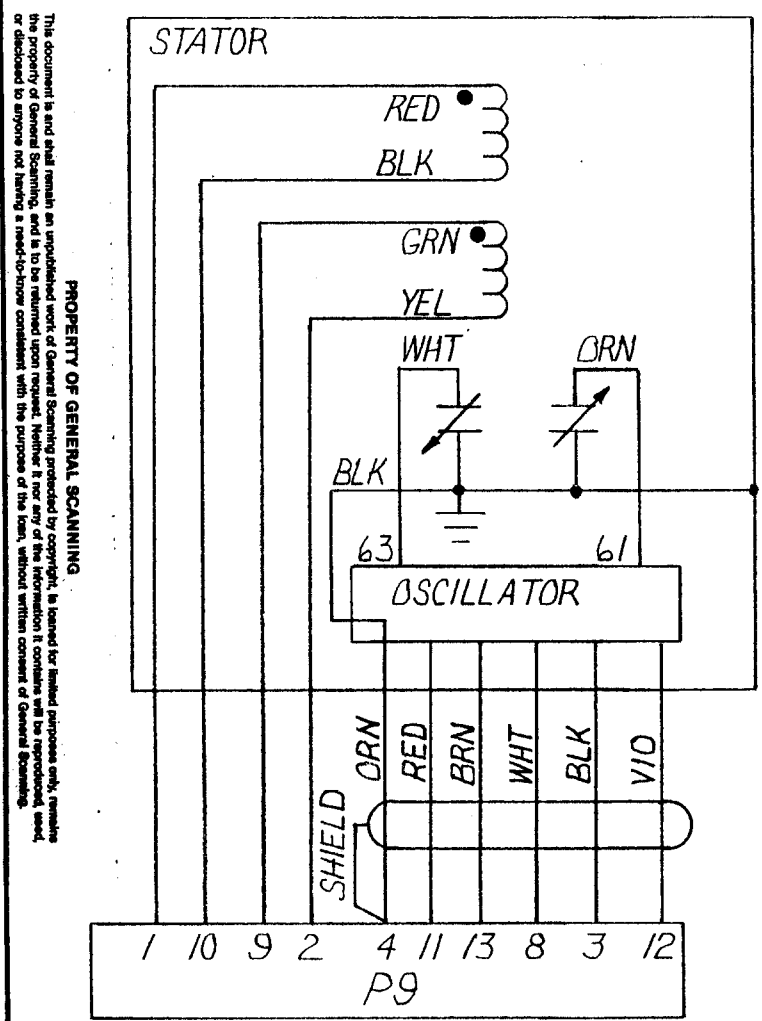

CONNECTOR PIN ASSIGNMENTS

1. DRIVE COIL RED
2. DRIVE COIL YELLOW
3. POSITION OUTPUT (-)
4. POSITION OUTPUT (COMMON)
5. N/C
6. N/C
7. N/C
8. OSCILLATOR SUPPLY VOLTAGE (+)
9. DRIVE COIL GREEN
10. DRIVE COIL BLACK
11. POSITION OUTPUT (+)
12. AGC OUTPUT
13. OSCILLATOR SUPPLY VOLTAGE (COMMON)
14. N/C
15. N/C

CONTROLLED
DOCUMENT

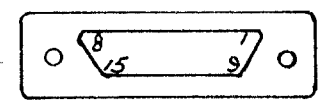

SOLDERABLE SIDE OF
CONNECTOR SHOWN

**A OPTICS
ORIGINAL PRINT**

MATERIAL				TREATMENT			
UNLESS SPECIFIED: DIMENSIONS ARE IN INCHES TOLERANCES: .XX = ± .01 .XXX = ± .005 .XXXX = ± .0010 ANG. = ± 0°30' REMOVE ALL BURRS AND SHARP EDGES.	FUNCTION	NAME	DATE				
	ORIGINATOR						
	CHECKER						USED ON
	Q.A.						TITLE
SCALE	DATE 7/1/85	PROJ. ENG.					WIRING DIAGRAM
DRAWN W. Grinsowicz		MFG. ENG.					GENERAL SCANNING
		ENG. MGR.					INCORPORATED WATERTOWN, MA.
					SIZE A	DRAWING NUMBER 3WD-09128	REV. A

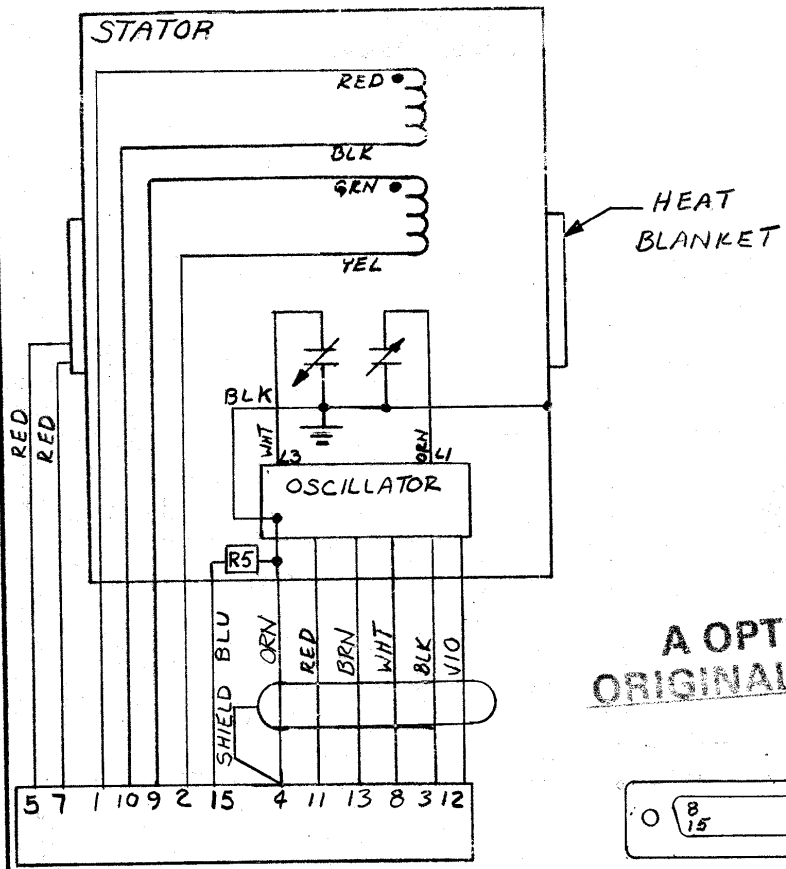

SYM	REVISION RECORD	DATE	APPVD.
A	RELEASED FOR PROD.	7/1/82	
B	PIN 8 WAS 14, CONNECTED VIA WIRE, ADDED ON COIL WINDING PER ECO 3587	4/22/83	ARC
C	REMOVED DETAIL FOR COIL CONFIG; ADDED CONN. PIN ASSIGNMENTS; ECO 4833	7-9-85	+Z

CONNECTOR PIN ASSIGNMENTS

1. DRIVE COIL RED
2. DRIVE COIL YELLOW
3. POSITION OUTPUT (-)
4. POSITION OUTPUT (COMMON)
5. HEATER BLANKET
6. N/C
7. HEATER BLANKET
8. OSCILLATOR SUPPLY VOLTAGE (+)
9. DRIVE COIL GREEN
10. DRIVE COIL BLACK
11. POSITION OUTPUT (+)
12. AGC OUTPUT
13. OSCILLATOR SUPPLY VOLTAGE (COMMON)
14. N/C
15. THERMISTOR

CONTROLLED DOCUMENT

A OPTICS ORIGINAL PRINT

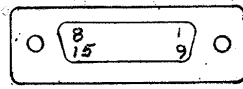

SOLDERABLE SIDE OF CONNECTOR SHOWN

PROPERTY OF GENERAL SCANNING

This document is and shall remain an unpublished work of General Scanning protected by copyright, is loaned for limited purposes only, remains the property of General Scanning, and is to be returned upon request. Neither it nor any of the information it contains will be reproduced, used or disclosed to anyone not having a need-to-know consistent with the purpose of the loan, without written consent of General Scanning.

UNLESS OTHERWISE SPECIFIED DIMENSIONS ARE IN INCHES TOLERANCES DECIMAL ANGULAR XX ± .01 ± 0° 30' XXX ± .005	SCALE NONE	DATE 5/10/82				
	DRAWN GLEN TOBIASON					
REMOVE ALL BURRS AND SHARP EDGES	CHECKED		USED ON			
MATERIAL	APPROVED		TITLE WIRING DIAGRAM			
TREATMENT	APPROVED		GENERAL SCANNING INCORPORATED WATERTOWN MA		SIZE A	DRAWING NUMBER 3WD-06525
						REV C

DWG NO. 3WD-18345 SH 1 REV B

REVISIONS				
ZONE	REV	DESCRIPTION	DATE	APPROVED
-	A	RELEASED TO PRODUCTION PER ECN 10929		
	B	REVISED PER ECN 980050		

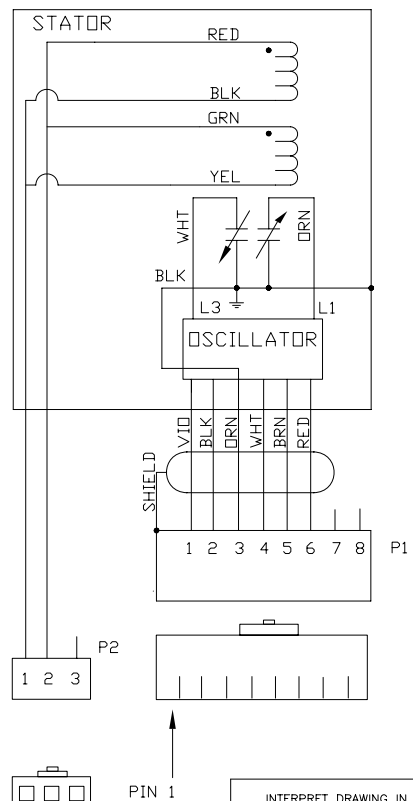

CONNECTOR PIN ASSIGNMENTS

- P1
1. AGC IN
 2. POS-
 3. GND
 4. OSC PWR
 5. GND
 6. POS+
- P2
1. GALVO LOW
 2. GALVO HIGH
 3. NO CONNECTION

INTERPRET DRAWING IN ACCORDANCE WITH DOD-STD-100, ANSI Y14.5M-1994

PROPERTY OF GENERAL SCANNING
THIS DOCUMENT IS AND SHALL REMAIN AN UNPUBLISHED WORK OF GENERAL SCANNING PROTECTED BY COPYRIGHT. IT IS LOANED FOR LIMITED PURPOSES ONLY, REMAINS THE PROPERTY OF GENERAL SCANNING AND IS TO BE RETURNED UPON REQUEST. NEITHER IT NOR ANY OF THE INFORMATION IT CONTAINS BE REPRODUCED, USED, OR DISCLOSED TO ANYONE HAVING A NEED-TO-KNOW CONSISTENT WITH THE PURPOSE OF THE LOAN, WITHOUT WRITTEN CONSENT OF GENERAL SCANNING.

UNLESS OTHERWISE SPECIFIED:
DIMENSIONS ARE IN INCHES
TOLERANCES ARE:
.X ± .1
.XX ± .01
.XXX ± .005
.XXXX ± .0010
ANGLES ± .5°
DO NOT SCALE DRAWING
REMOVE ALL BURRS AND BREAK SHARP EDGES

ALL MACH SURFACES ϕ
THIRD ANGLE PROJECTION

CONTRACT NO.	
DRAWN A. VALLEE	5/2/97
DESIGN ENGR J.W. KING	5/19/97
MFG D.C. BROWN	5/19/97
Q.A. D. GOSSE	5/19/97
APPD	
APPD	
CAD FILE NAME 18345-0B	98.03.12/13:33

GENERAL SCANNING INC. OPTICAL SCANNING PRODUCTS DIVISION 500 ARSENAL STREET, WATERTOWN, MA. 02172			
WIRING DIAGRAM, G1__DS SERIES			
SIZE B	CAGE CODE 57246	DWG NO. 3WD-18345	REV B
SCALE NONE			SHEET 1 OF 1

X		RELEASED	XX
SHT 2	SHT 1	NUMBER	2
CAD FILE REV.			

NOTES:

1.

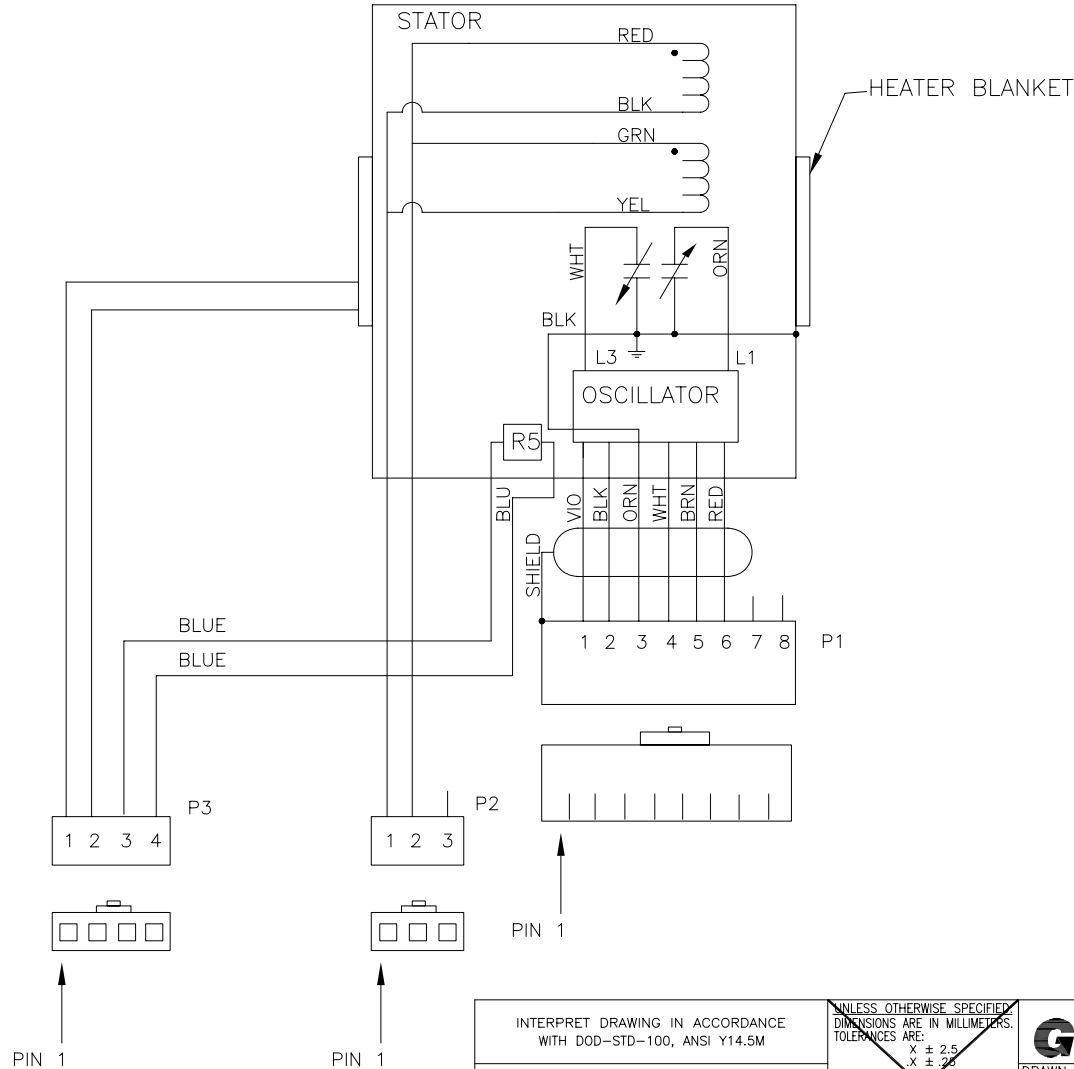

REVISIONS				
ZONE	REV	DESCRIPTION	DATE	APPROVED
-	A	RELEASED PER ECO #10929		
	B	REVISED PER ECN 980050		
	C	REVISED PER ECN 2003-194	8-11-03	D.O

CONNECTOR PIN ASSIGNMENTS

- P1
1. AGC IN
 2. POS-
 3. GND
 4. OSC PWR
 5. GND
 6. POS+
- P2
1. GALVO LOW
 2. GALVO HIGH
 3. NO CONNECTION
- P3
1. HEATER HIGH
 2. HEATER LOW
 3. THERMISTOR 1
 4. THERMISTOR 2

UNLESS OTHERWISE SPECIFIED:
 DIMENSIONS ARE IN INCHES
 TOLERANCES ARE:
 .X ± .1
 .XX ± .01
 .XXX ± .005
 .XXXX ± .0010
 ANGLES ± .5°
 DO NOT SCALE DRAWING
 REMOVE ALL BURRS AND BREAK
 SHARP EDGES 6.3
 ALL MACH SURFACES ✓

INTERPRET DRAWING IN ACCORDANCE WITH DOD-STD-100, ANSI Y14.5M

PROPERTY OF GSI LUMONICS
 THIS DOCUMENT IS AND SHALL REMAIN AN UNPUBLISHED WORK OF GSI LUMONICS PROTECTED BY COPYRIGHT. IS LOANED FOR LIMITED PURPOSES ONLY, REMAINS THE PROPERTY OF GSI LUMONICS, AND IS TO BE RETURNED UPON REQUEST. NEITHER IT NOR ANY OF THE INFORMATION IT CONTAINS WILL BE REPRODUCED, USED, OR DISCLOSED TO ANYONE NOT HAVING A NEED-TO-KNOW CONSISTENT WITH THE PURPOSE OF THE LOAN, WITHOUT WRITTEN CONSENT OF GSI LUMONICS.

UNLESS OTHERWISE SPECIFIED, DIMENSIONS ARE IN MILLIMETERS. TOLERANCES ARE:
 X ± 2.5
 .X ± .25
 .XX ± .13
 .XXX ± .025
 ANGLES ± .5°
 DO NOT SCALE DRAWING
 REMOVE ALL BURRS AND BREAK SHARP EDGES
 ALL MACHINED SURFACES 1.6 MICRON Ra

THIRD ANGLE PROJECTION

GSI Lumonics COMPONENT PRODUCTS GROUP

WIRING DIAGRAM
 G120DTS

DRAWN A.L.	1-22-97	SIZE B	CAGE CODE 57246	DWG NO. 3WD-18198	REV C
DESIGN ENG D.BROWN	9-17-97	SCALE 1/1	SHEET 1 OF 1		
MFG ENG T.GOSSE	5-19-97	CAD FILE NAME:			

SYM	REVISION	RECORD	DATE	APPV.
C	REDRAWN PER ECO 4641		2/8/85	TZ
D	REMOVED DETAIL 'A' ADDED CONN. ASSIGNMENTS	ECO 4833	7-9-85	TZ

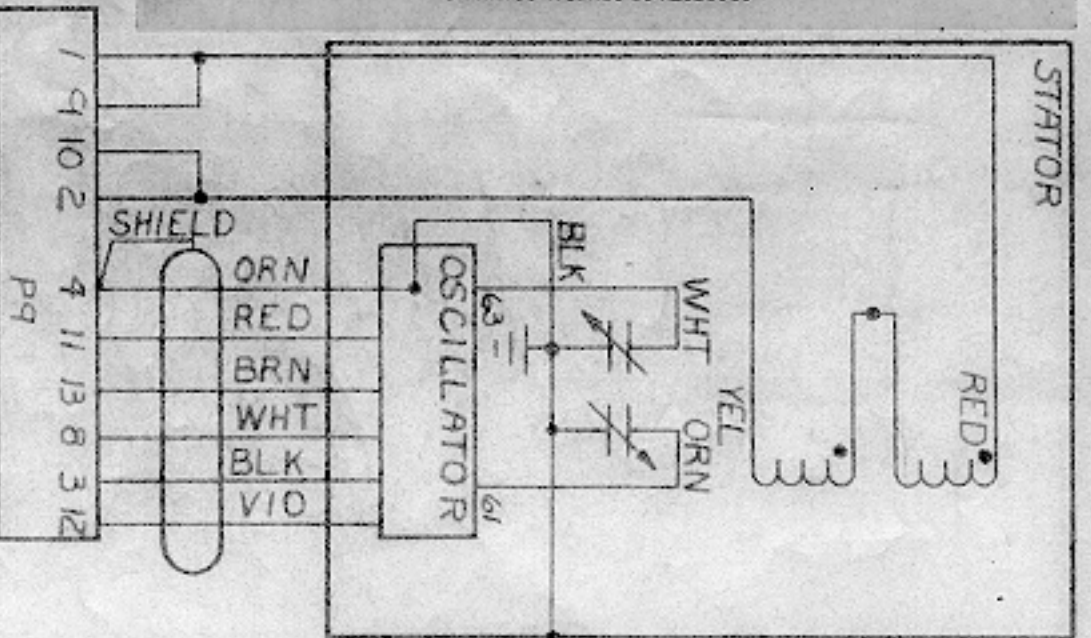

A OPTICS ORIGINAL PRINT

CONNECTOR PIN ASSIGNMENTS

1. DRIVE COIL RED
2. DRIVE COIL YELLOW
3. POSITION OUTPUT (-)
4. POSITION OUTPUT (COMMON)
5. N/C
6. N/C
7. N/C
8. OSCILLATOR SUPPLY VOLTAGE (+)
9. DRIVE COIL RED
10. DRIVE COIL YELLOW
11. POSITION OUTPUT (+)
12. AGC OUTPUT
13. OSCILLATOR SUPPLY VOLTAGE (COMMON)
14. N/C
15. N/C



SOLDERABLE SIDE OF CONNECTOR SHOWN

DOCUMENT

MATERIAL

UNLESS SPECIFIED:
DIMENSIONS ARE IN INCHES
TOLERANCES: .XX = ±.01
.XXX = ±.005
.XXXX = ±.0010
ANG. = ±0°30'

REMOVE ALL BURRS AND SHARP EDGES.

FUNCTION	NAME	DATE
ORIGINATOR		
CHECKER		
O.A.		
PROJ. ENG.		1-28-85
MFG. ENG.		
ENG. MGR.		

WIRING DIAGRAM

GENERAL SCANNING

INCORPORATED WATERLOWN, MA.	SIZE A	DRAWING NUMBER 3WD-06524	REV. D
-----------------------------	---------------	---------------------------------	---------------

SYM	REVISION	RECORD	DATE	BY
A			5-2-84	
B	REVERSED 10 & 9 (10 & 9) PER EACH		8-29-84	
C	REVISED PER ECO 4641		3-9-85	
D	REVERSED COIL SAID TO BE REPAIR - DRIVER COIL PIN ASSIGNMENTS	ECO 4833	7-9-85	JZ

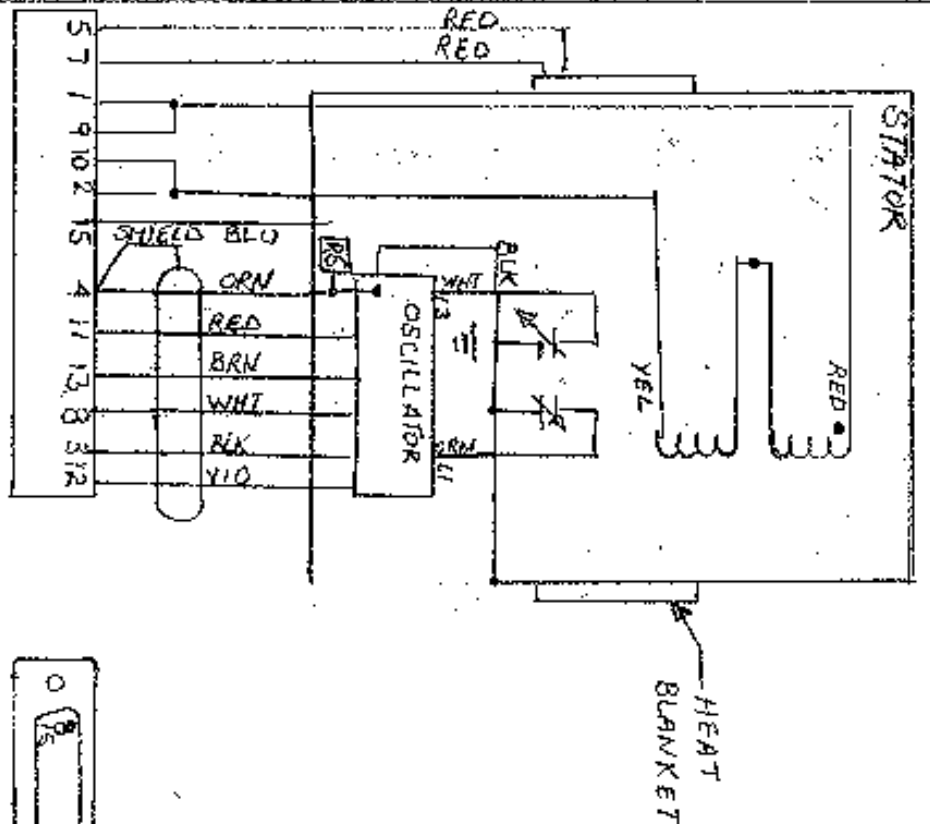

CONNECTOR PIN ASSIGNMENTS

1. DRIVE COIL RED
2. DRIVE COIL YELLOW
3. POSITION OUTPUT (-)
4. POSITION OUTPUT (COMMON)
5. HEATER BLANKET
6. N/C
7. HEATER BLANKET
8. OSCILLATOR SUPPLY VOLTAGE (+)
9. DRIVE COIL RED
10. DRIVE COIL YELLOW
11. POSITION OUTPUT (+)
12. AGC OUTPUT
13. OSCILLATOR SUPPLY VOLTAGE (-)
14. N/C
15. TRANSISTOR

APPROX
SOLDERABLE SIDE ORIGINAL PRINT
CONNECTOR SHOWN

PROPERTY OF GENERAL SCANNING
 This document is and shall remain the property of General Scanning, Inc. It is loaned to you for your use only. It is not to be reproduced, copied, or distributed in any form without the written consent of General Scanning, Inc. If you are unable to return this document to the person from whom it was loaned, please contact General Scanning, Inc. at the address below.

UNLESS OTHERWISE SPECIFIED
 DIMENSIONS ARE IN INCHES
 TOLERANCES DECIMAL ANGULAR
 XX ±.01 ± D° 30'
 REMOVE ALL BURRS AND SHARP EDGES
 MATERIAL

SCALE DATE
 6:21-84
 DRAWN BY
 BRADBURY
 CHECKED BY
 APPROVED
 TITLE
 WIRING DIAGRAM
 USED ON

TREATMENT APPROVED
 GENERAL SCANNING SIZE DRAWING
 INCORPORATED WATERLOO, MA A 3WD-08042 D